

# Operating Instructions

## Indumax CLS54

Conductivity sensor

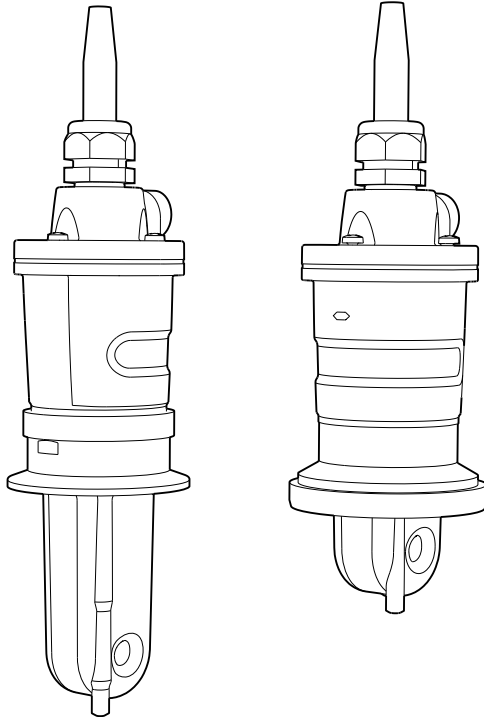

# EU Declaration of Conformity

**EU-Konformitätserklärung**  
**EU-Declaration of Conformity**  
**Déclaration UE de Conformité**

**Endress+Hauser**   
 People for Process Automation



**Company** **Endress+Hauser Conducta GmbH+Co. KG**  
**Dieselstraße 24, 70839 Gerlingen, Germany**  
 erklärt als Hersteller in alleiniger Verantwortung, dass das Produkt  
 declares as manufacturer under sole responsibility, that the product  
 déclare sous sa seule responsabilité en qualité de fabricant que le produit

**Product** **Indumax**  
 CLS54-G\*\*\*\*\*

**Regulations** den folgenden Europäischen Richtlinien entspricht:  
 conforms to following European Directives:  
 est conforme aux prescription des Directives Européennes suivantes :

EMC 2014/30/EU (L96/79)  
 ATEX 2014/34/EU (L96/309)

**Standards** angewandte harmonisierte Normen oder normative Dokumente:  
 applied harmonized standards or normative documents:  
 normes harmonisées ou documents normatifs appliqués :

EN 61326-1 (2013) EN 60079-0 (2012) + A11 (2013)  
 EN 61326-2-3 (2013) EN 60079-11 (2012)

**Certification** EG-Baumusterprüfbescheinigung Nr. BVS 07 ATEX E 158 X  
 EC-Type Examination Certificate No.  
 Numéro de l'attestation d'examen CE de type  
 Ausgestellt von/issued by/dé livré par DEKRA EXAM GmbH (0158)  
 Qualitätssicherung/Quality assurance/Système d'assurance qualité DEKRA EXAM GmbH (0158)  
 Gerlingen, 09.08.2016  
 Endress+Hauser Conducta GmbH+Co. KG

  
 i. V. Jörg-Martin Müller  
 Technology





  
 i. V. Robert Binder  
 Technology Certifications and  
 Approvals

# Table of contents







<b>1</b>	<b>About this document</b> .....	<b>4</b>	<b>Index</b> .....	<b>26</b>
1.1	Warnings .....	4		
1.2	Symbols used .....	4		
1.3	Symbols on the device .....	5		
<b>2</b>	<b>Basic safety instructions</b> .....	<b>6</b>		
2.1	Requirements for personnel .....	6		
2.2	Designated use .....	6		
2.3	Workplace safety .....	6		
2.4	Operational safety .....	6		
2.5	Product safety .....	7		
<b>3</b>	<b>Incoming acceptance and product identification</b> .....	<b>8</b>		
3.1	Incoming acceptance .....	8		
3.2	Product identification .....	8		
3.3	Scope of delivery .....	10		
3.4	Certificates and approvals .....	10		
<b>4</b>	<b>Installation</b> .....	<b>12</b>		
4.1	Installation conditions .....	12		
4.2	Mounting the sensor .....	17		
4.3	Post-installation check .....	17		
<b>5</b>	<b>Electrical connection</b> .....	<b>17</b>		
5.1	Connection conditions .....	18		
5.2	Connecting the sensor .....	18		
5.3	Ensuring the degree of protection .....	19		
5.4	Post-connection check .....	19		
<b>6</b>	<b>Maintenance</b> .....	<b>20</b>		
<b>7</b>	<b>Repair</b> .....	<b>20</b>		
7.1	Return .....	20		
7.2	Disposal .....	21		
<b>8</b>	<b>Accessories</b> .....	<b>21</b>		
8.1	Cable extension .....	21		
8.2	Calibration solutions .....	22		
<b>9</b>	<b>Technical data</b> .....	<b>22</b>		
9.1	Input .....	22		
9.2	Performance characteristics .....	22		
9.3	Environment .....	23		
9.4	Process .....	23		
9.5	Mechanical construction .....	24		

# 1 About this document

## 1.1 Warnings

Structure of information	Meaning
 <p><b>Causes (/consequences)</b> If necessary, Consequences of non-compliance (if applicable) ▶ Corrective action</p>	<p>This symbol alerts you to a dangerous situation. Failure to avoid the dangerous situation <b>will</b> result in a fatal or serious injury.</p>
 <p><b>Causes (/consequences)</b> If necessary, Consequences of non-compliance (if applicable) ▶ Corrective action</p>	<p>This symbol alerts you to a dangerous situation. Failure to avoid the dangerous situation <b>can</b> result in a fatal or serious injury.</p>
 <p><b>Causes (/consequences)</b> If necessary, Consequences of non-compliance (if applicable) ▶ Corrective action</p>	<p>This symbol alerts you to a dangerous situation. Failure to avoid this situation can result in minor or more serious injuries.</p>
 <p><b>Cause/situation</b> If necessary, Consequences of non-compliance (if applicable) ▶ Action/note</p>	<p>This symbol alerts you to situations which may result in damage to property.</p>

## 1.2 Symbols used

Symbol	Meaning
	Additional information, tips
	Permitted or recommended
	Not permitted or not recommended
	Reference to device documentation
	Reference to page
	Reference to graphic
	Result of a step

### 1.3 Symbols on the device

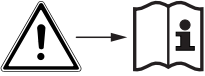
Symbol	Meaning
	Reference to device documentation

## 2 Basic safety instructions

### 2.1 Requirements for personnel

- Installation, commissioning, operation and maintenance of the measuring system may be carried out only by specially trained technical personnel.
- The technical personnel must be authorized by the plant operator to carry out the specified activities.
- The electrical connection may be performed only by an electrical technician.
- The technical personnel must have read and understood these Operating Instructions and must follow the instructions contained therein.
- Faults at the measuring point may only be rectified by authorized and specially trained personnel.



Repairs not described in the Operating Instructions provided must be carried out only directly at the manufacturer's site or by the service organization.

### 2.2 Designated use

Indumax CLS54 is designed for the inductive measurement of the conductivity of liquids. The sensor is particularly suitable for use in hygienic applications in the food, beverage, pharmaceutical and biotech industry.

Use with Liquiline CM42, and Liquisys CLM223/253 transmitters; part of the Smartec CLD134 measuring system.

Use of the device for any purpose other than that described, poses a threat to the safety of people and of the entire measuring system and is therefore not permitted.

The manufacturer is not liable for damage caused by improper or non-designated use.

### 2.3 Workplace safety

As the user, you are responsible for complying with the following safety conditions:

- Installation guidelines
- Local standards and regulations
- Regulations for explosion protection

#### **Electromagnetic compatibility**

- The product has been tested for electromagnetic compatibility in accordance with the applicable international standards for industrial applications.
- The electromagnetic compatibility indicated applies only to a product that has been connected in accordance with these Operating Instructions.

### 2.4 Operational safety

#### **Before commissioning the entire measuring point:**

1. Verify that all connections are correct.
2. Ensure that electrical cables and hose connections are undamaged.
3. Do not operate damaged products, and protect them against unintentional operation.

4. Label damaged products as defective.

### During operation:

- ▶ If faults cannot be rectified:  
products must be taken out of service and protected against unintentional operation.

## 2.5 Product safety

### 2.5.1 State-of-the-art technology

The product is designed to meet state-of-the-art safety requirements, has been tested, and left the factory in a condition in which it is safe to operate. The relevant regulations and international standards have been observed.

### 2.5.2 Electrical equipment in hazardous areas

The sensor may be connected to the following transmitters:

- Liquiline M CM42, EC type-examination certificates TÜV 13 ATEX 7459 X, TÜV 14 ATEX 7510 X, TÜV 14 ATEX 7509 X, EX5 05 03 30266 012
- Mycom S CLM153-G, EC type-examination certificate DMT 01 ATEX E 174

#### CLS54-G\*\*\*\*\* and CLS54-K\*\*\*\*\*

- The sensor has been developed and manufactured in accordance with the applicable European standards and guidelines and is suitable for use in hazardous areas.
- The Declaration of Conformity confirms compliance with the harmonized European standards for using the sensor in hazardous areas and is included in the Operating Instructions.
- The sensor must be connected and operated in accordance with the associated Operation Instructions. All sensor operating data must be observed.
- Ensure that it is professionally installed in order to achieve the degree of protection (IP65) for the housing. Use the original seal, and install the cable entry properly.
- Compliance with the specified ambient and process temperature ranges is a prerequisite for safe use of the device!
- The sensors may only be used in liquid media with a conductivity  $>10$  nS/cm.
- To avoid electrostatic charges, all CLS54 versions with metal surfaces (depends on process connection) must be electrostatically connected in such a way that  $R \leq 1$  M $\Omega$ .
- The maximum permitted length of the measuring cable is 50 m.
- Full compliance with regulations for electrical systems in hazardous areas (EN 60079-14) is mandatory when using the devices and sensors.

### Temperature classes

Temperature class	Ambient temperature range $T_a$	Medium temperature range $T_{med}$
T6	-20 °C to +60 °C	$-10\text{ °C} \leq T_{med} \leq +55\text{ °C}$
T4		$-10\text{ °C} \leq T_{med} \leq +105\text{ °C}$
T3		$-10\text{ °C} \leq T_{med} \leq +125\text{ °C}^{1)}$

1) 150 °C for maximum 60 min

**Sensors with CSA approval (CLS504-O\*\*\*\*\*)**

Observe the documentation and the control drawings of the transmitter.

### 3 Incoming acceptance and product identification

#### 3.1 Incoming acceptance

1. Verify that the packaging is undamaged.
  - ↳ Notify the supplier of any damage to the packaging.  
Keep the damaged packaging until the issue has been resolved.
2. Verify that the contents are undamaged.
  - ↳ Notify the supplier of any damage to the delivery contents.  
Keep the damaged goods until the issue has been resolved.
3. Check that the delivery is complete and nothing is missing.
  - ↳ Compare the shipping documents with your order.
4. Pack the product for storage and transportation in such a way that it is protected against impact and moisture.
  - ↳ The original packaging offers the best protection.  
Make sure to comply with the permitted ambient conditions.

If you have any questions, please contact your supplier or your local Sales Center.

#### 3.2 Product identification

##### 3.2.1 Type code for versions with explosion protection

Name	Type	Version							
Indumax	CLS54	-	G	xxx	x	x	x	+	x
			for use in hazardous areas, ATEX II 1G Ex ia IIC T3/T4/T6 Ga	Process connections, additional options, cable connection, temperature sensor, identification No Ex relevance					

Name	Type	Version							
Indumax	CLS54	-	O	xxx	x	x	x	+	x
			For use in hazardous areas, CSA IS NI Cl.I Div.1&2, Gr. A-D	Process connections, additional options, cable connection, temperature sensor, identification No Ex relevance					



Name	Type	Version							
Indumax	CLS54	-	K	xxx	x	x	x	+	x
			For use in hazardous areas, EAC Ex, OEx ia IIC T6/T4 Ga X	Process connections, additional options, cable connection, temperature sensor, identification No Ex relevance					

### 3.2.2 Nameplate

The nameplate can be found on the sensor.

The following information is provided on the nameplate:

- Manufacturer identification
- Order code
- Extended order code
- Serial number
- Cell constant (nominal value)
- Protection class
- Pressure specification at 20 °C
- Continuous service temperature



Compare the data on the nameplate with your order.

### 3.2.3 Product identification

#### Product page

[www.endress.com/cls54](http://www.endress.com/cls54)

#### Interpreting the order code

The order code and serial number of your product can be found in the following locations:

- On the nameplate
- In the delivery papers

#### Obtaining information on the product

1. Go to [www.endress.com](http://www.endress.com).
2. Call up the site search (magnifying glass).
3. Enter a valid serial number.
4. Search.
  - ↳ The product structure is displayed in a popup window.
5. Click on the product image in the popup window.
  - ↳ A new window (**Device Viewer**) opens. All of the information relating to your device is displayed in this window as well as the product documentation.

## Manufacturer's address

Endress+Hauser Conducta GmbH+Co. KG  
Dieselstraße 24  
D-70839 Gerlingen

## 3.3 Scope of delivery

The scope of delivery includes:

- Sensor in the version ordered
- Operating Instructions
- ▶ If you have any queries:  
Please contact your supplier or local sales center.

## 3.4 Certificates and approvals

### 3.4.1 CE mark

#### Declaration of Conformity

The product meets the requirements of the harmonized European standards. As such, it complies with the legal specifications of the EU directives. The manufacturer confirms successful testing of the product by affixing to it the CE mark.

### 3.4.2 Ex approvals

- ATEX II 1G Ex ia IIC T3/T4/T6
- CSA IS/NI Cl. I Div. 1 & 2 GP A - D in conjunction with the Liquiline M CM42 transmitter
- EAC Ex, OEx ia IIC T6/T4 Ga X
  - Zone 0
  - Certificate number: TC RU C-DE.AA87.B.00088
  - The product has been certified in accordance with Directive TR CU 012/2011 which applies in the European Economic Area (EEA). The EAC conformity mark has been affixed to the product.

### 3.4.3 Hygiene

#### FDA

All materials in contact with the product are listed by the FDA.

#### EHEDG

Certified cleanability according to EHEDG TYPE EL-class I.



When using the sensor in hygienic applications, please note that the cleanability of the sensor also depends on the way the sensor is installed. To install the sensor in a pipe, use the appropriate and EHEDG-certified flow vessels for the particular process connection.

#### 3-A

Certified according to 3-A Standard 74- ("3-A Sanitary Standards for Sensor and Sensor Fittings and Connections Used on Milk and Milk Products Equipment").

**Biological reactivity (USP class VI) (option)**

Biological reactivity test certificate (Certificate of Compliance) according to USP (United States Pharmacopoeia) part <87> and part <88> class VI with lot number traceability of materials in contact with the medium.

**3.4.4 Regulation (EC) No. 1935/2004**

Meets the requirements of Regulation (EC) No. 1935/2004

**3.4.5 Pressure approval**

Canadian pressure approval for pipes according to ASME B31.3

# 4 Installation

## 4.1 Installation conditions

### 4.1.1 Dimensions

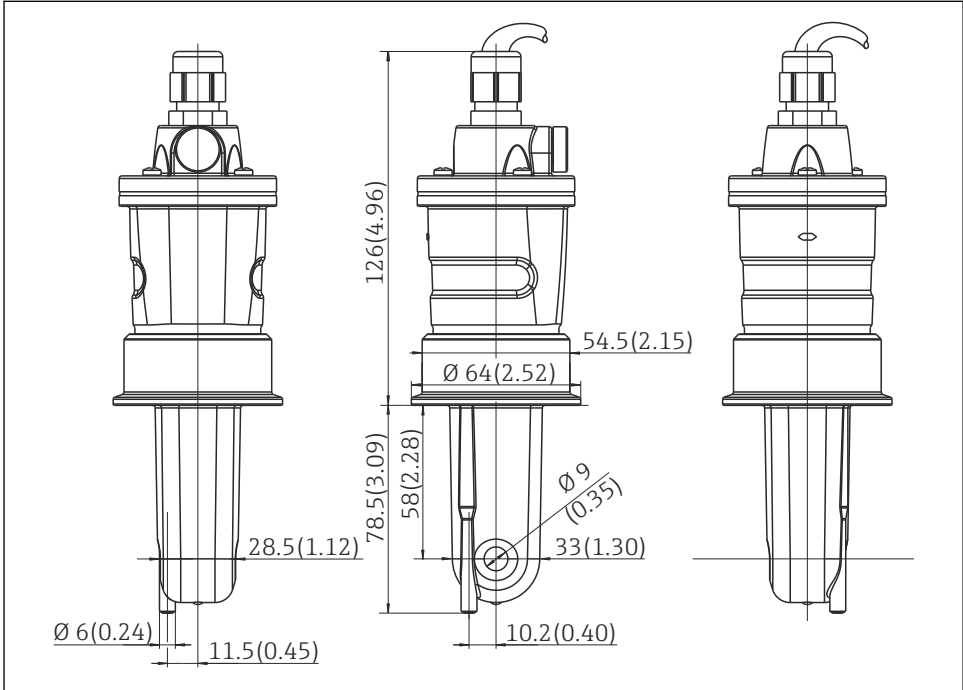

A0005429

1 Dimensions in mm(inch) (long version)

## Process connections

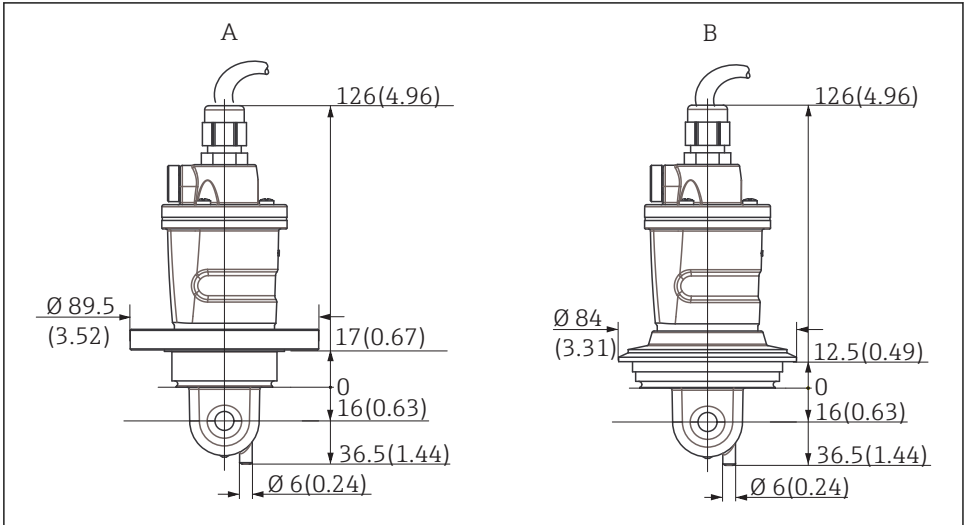

A0037964

### 2 Process connections for CLS54 (short version), dimensions in mm (inch)

A NEUMO BioControl D50 for pipe connection: DN 40 (DIN 11866 series A, DIN 11850); DN 42.4 (DIN 11866 series B, DIN EN ISO 1127); 2" (DIN 11866 series C, ASME-BPE)

B Varivent N DN 40 to 125

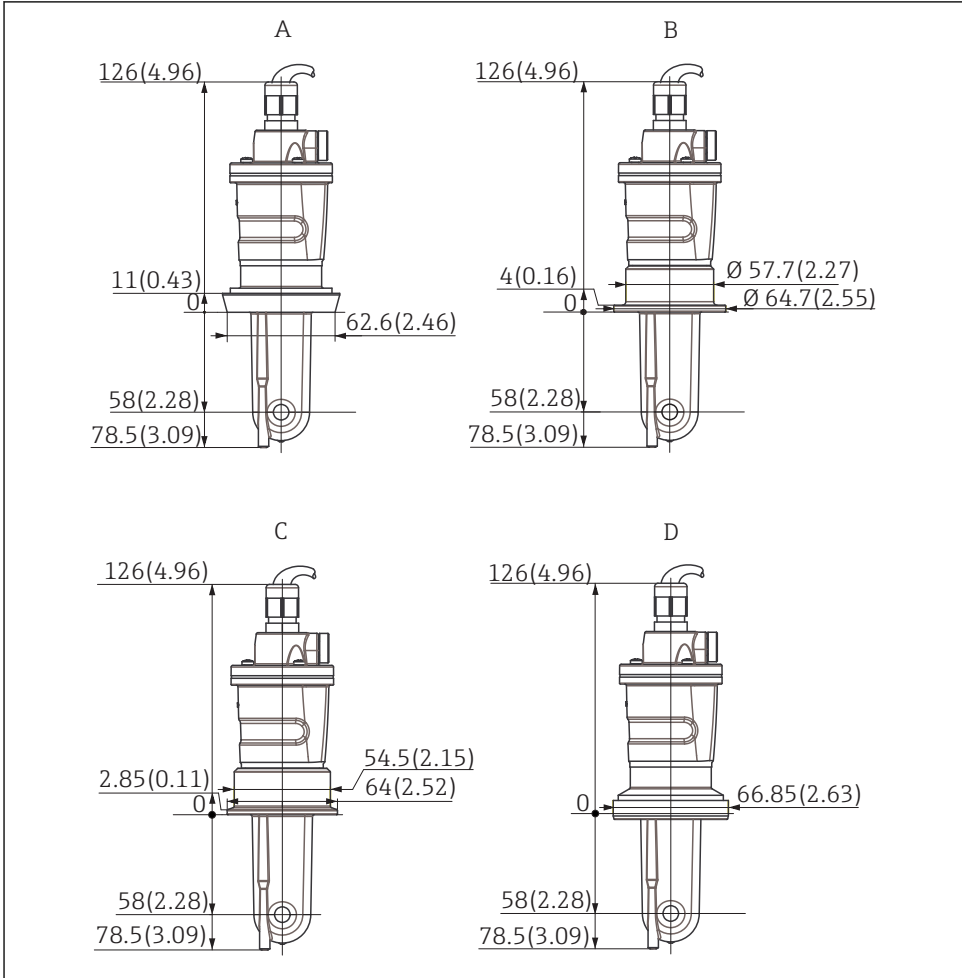

A0037965

3 Process connections for CLS54 (long version), dimensions in mm (inch)

- A Sanitary connection DIN 11851, DN 50
- B SMS coupling 2"
- C Clamp ISO 2852, 2"
- D Aseptic coupling DIN 11864-1 form A, for pipe according to DIN 11850, DN 50

#### 4.1.2 Hygienic requirements

For 3-A-compliant installation, please observe the following:

- After the device has been mounted, hygienic integrity must be guaranteed.
- 3-A-compliant process connections must be used.

### 4.1.3 Orientation

The sensor must be completely immersed in the medium. Avoid air bubbles in the area of the sensor.

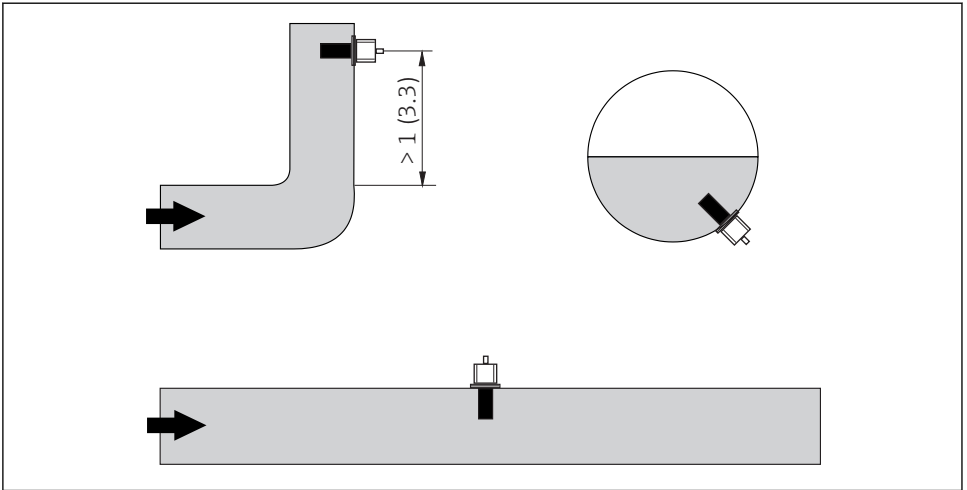

A0037970

4 Installation positions of the conductivity sensor



Changes in the flow direction (after pipe bends) can cause turbulence in the medium. Install the sensor at a distance of at least 1 m (3.3 ft) downstream from a pipe bend.

The product should flow along the hole of the sensor (see the arrows on the housing). The symmetrical measuring channel allows flow in both directions.

### 4.1.4 Installation factor

The ionic current in the liquid is affected by the walls in confined installation conditions. This effect is compensated by what is referred to as the installation factor. The installation factor can be entered in the transmitter for the measurement or the cell constant is corrected by multiplying by the installation factor.

The value of the installation factor depends on the diameter and the conductivity of the pipe nozzle as well as the distance  $a$  between the sensor and the wall.

The installation factor  $f$  ( $f = 1.00$ ) can be disregarded if the distance to the wall is sufficient ( $a > 15$  mm, from DN 65).

If the distance to the wall is smaller, the installation factor increases for electrically insulating pipes ( $f > 1$ ), and decreases for electrically conductive pipes ( $f < 1$ ).

It can be measured using calibration solutions, or a close approximation can be determined from the diagram below.

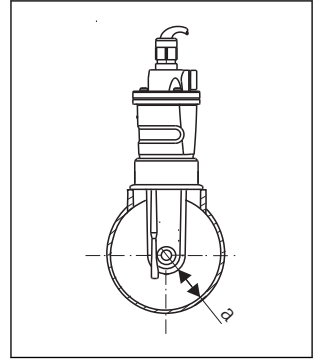

A0032680

5 Installation CLS54

$a$  Wall distance

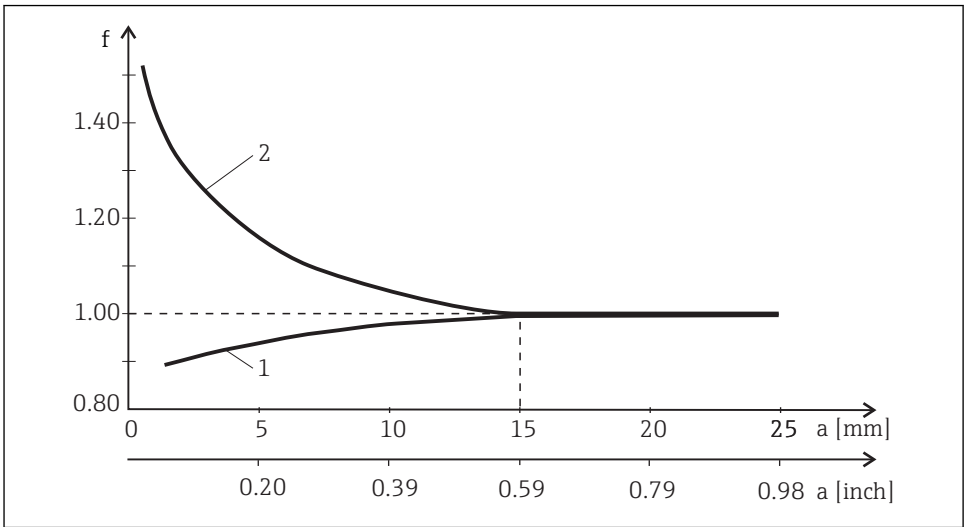

A0034874

6 Relationship between installation factor  $f$  and wall distance  $a$

- 1 Electrically conductive pipe wall
- 2 Electrically insulating pipe wall

### 4.1.5 Air set

To compensate residual coupling in the cable and between the two sensor coils, zero adjustment in air ("air set") must be performed before installing the sensor. Follow the instructions provided in the Operating Instructions of the transmitter used.



## 4.2 Mounting the sensor

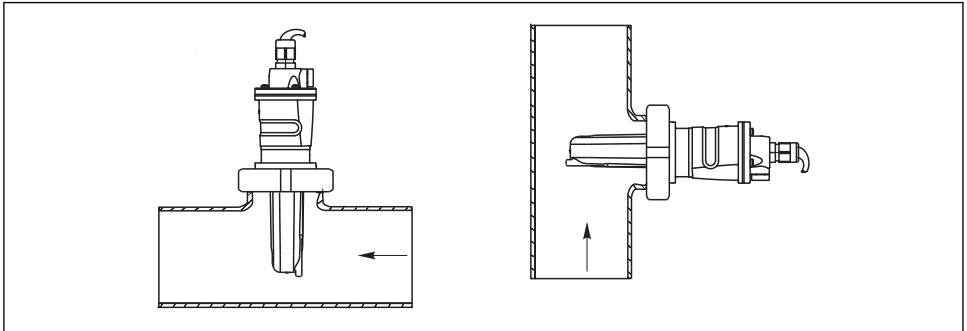

A0028428

7 Installation of CLS54, arrow indicates direction of flow

When installing, align the sensor in such a way that the medium flows through the flow opening of the sensor in the direction of medium flow. The sensor head must be completely immersed in the medium.

The symmetrical measuring channel allows flow in both directions.

## 4.3 Post-installation check

Put the sensor into operation only if you can answer yes to the following questions:

1. Are the sensor and cable undamaged?
2. Is the orientation correct?
3. Has the sensor been installed in the process connection, and does not suspend freely from the cable?

## 5 Electrical connection

### **⚠ WARNING**

#### **Device is live!**

Incorrect connection may result in injury or death!

- ▶ The electrical connection may be performed only by an electrical technician.
- ▶ The electrical technician must have read and understood these Operating Instructions and must follow the instructions contained therein.
- ▶ **Prior** to commencing connection work, ensure that no voltage is present on any cable.

## 5.1 Connection conditions

### 5.1.1 Connection diagram: sensors for Zone 0 (ATEX/EAC Ex)

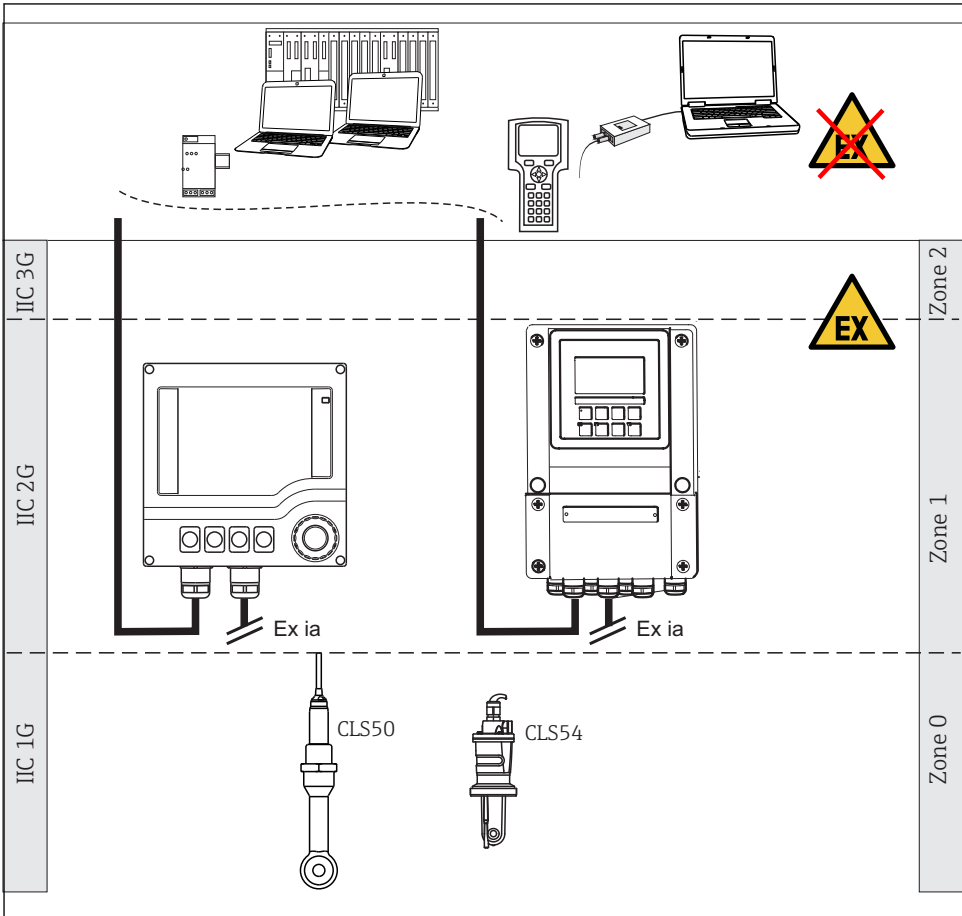

A0032676

### 5.1.2 Sensors with CSA approval

The instructions in the Control Drawing apply for sensors with FM or CSA approval. You can find the Control Drawing in the Operating Instructions of the transmitter used.

## 5.2 Connecting the sensor

The sensor is supplied with a fixed cable. The wiring diagram is provided in the Operating Instructions of the transmitter used.

Connection via a VBM junction box is necessary for a cable connection. The extension to the transmitter is via the CLK6 cable.

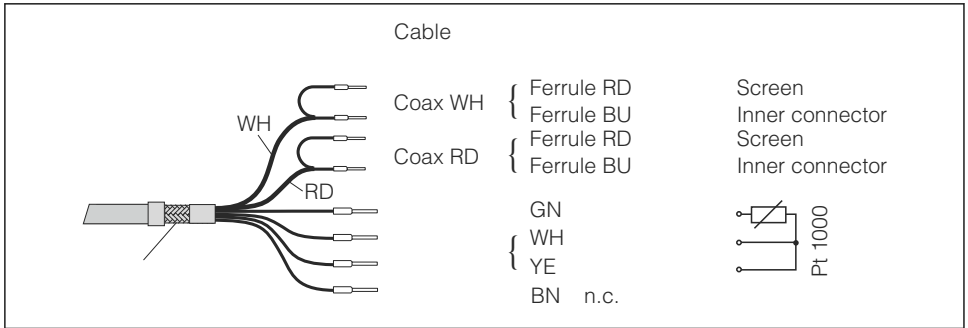

A0005433-EN

8 Fixed cable / measuring cable CLK6

Cable length: maximum 55 m (180 ft) total length (non-Ex versions)  
 maximum 50 m (180 ft) total length (Ex versions)

### 5.3 Ensuring the degree of protection

Only the mechanical and electrical connections which are described in these instructions and which are necessary for the required, designated use, may be carried out on the device delivered.

- ▶ Exercise care when carrying out the work.

Otherwise, the individual types of protection (Ingress Protection (IP), electrical safety, EMC interference immunity) agreed for this product can no longer be guaranteed due, for example to covers being left off or cable (ends) that are loose or insufficiently secured.

### 5.4 Post-connection check

Device condition and specifications	Action
Are the sensor, assembly or cables free from damage on the outside?	▶ Perform a visual inspection.
Electrical connection	Action
Are the mounted cables strain-relieved and not twisted?	▶ Perform a visual inspection. ▶ Untwist the cables.
Is a sufficient length of the cable cores stripped, and are the cores positioned in the terminal correctly?	▶ Perform a visual inspection. ▶ Pull gently to check they are seated correctly.
Are all the screw terminals properly tightened?	▶ Tighten the screw terminals.

Device condition and specifications	Action
Are all cable entries mounted, tightened and leak-tight?	▶ Perform a visual inspection.
Are all cable entries installed downwards or mounted laterally?	In the case of lateral cable entries: ▶ Point cable loops downward so that water can drip off.

## 6 Maintenance

### WARNING

#### Thiocarbamide

Harmful if swallowed! Limited evidence of carcinogenicity! Possible risk of harm to the unborn child! Dangerous for the environment with long-term effects!

- ▶ Wear protective goggles, protective gloves and appropriate protective clothing.
- ▶ Avoid all contact with the eyes, mouth and skin.
- ▶ Avoid discharge into the environment.

Clean away fouling on the sensor as follows depending on the type of fouling:

1. Oily and greasy films:  
Clean with fat solvent, e.g. alcohol, or hot water and agents containing surfactants (alkaline) (e.g. dishwashing detergent).
2. Lime and metal hydroxide buildup and low solubility (lyophobic) organic buildup:  
Dissolve buildup with diluted hydrochloric acid (3 %) and then rinse thoroughly with plenty of clear water.
3. Sulfidic buildup (from flue gas desulfurization or wastewater treatment plants):  
Use a mixture of hydrochloric acid (3 %) and thiocarbamide (commercially available) and then rinse thoroughly with plenty of clear water.
4. Buildup containing proteins (e.g. food industry):  
Use a mixture of hydrochloric acid (0.5 %) and pepsin (commercially available) and then rinse thoroughly with plenty of clear water.
5. Readily soluble biological buildup:  
Rinse with pressurized water.

After cleaning, rinse the sensor thoroughly with water.

## 7 Repair

### 7.1 Return

The product must be returned if repairs or a factory calibration are required, or if the wrong product was ordered or delivered. As an ISO-certified company and also due to legal

regulations, Endress+Hauser is obliged to follow certain procedures when handling any returned products that have been in contact with medium.

To ensure the swift, safe and professional return of the device:

- ▶ Refer to the website [www.endress.com/support/return-material](http://www.endress.com/support/return-material) for information on the procedure and conditions for returning devices.

## 7.2 Disposal



If required by the Directive 2012/19/EU on waste electrical and electronic equipment (WEEE), the product is marked with the depicted symbol in order to minimize the disposal of WEEE as unsorted municipal waste. Do not dispose of products bearing this marking as unsorted municipal waste. Instead, return them to Endress+Hauser for disposal under the applicable conditions.

# 8 Accessories

The following are the most important accessories available at the time this documentation was issued.

- ▶ For accessories not listed here, please contact your Service or Sales Center.

## 8.1 Cable extension

### 8.1.1 Measuring cable

#### Measuring cable CLK6

- Extension cable for inductive conductivity sensors, for extension via VBM junction box
- Sold by the meter, order number: 71183688

### 8.1.2 Junction box

#### VBM

- Junction box for cable extension
- 10 terminal strips
- Cable entries: 2 x Pg 13.5 or 2 x NPT ½"
- Material: aluminum
- Degree of protection: IP 65
- Order numbers
  - Cable entries Pg 13.5 : 50003987
  - Cable entries NPT ½": 51500177

#### Desiccant pouch

- Desiccant pouch with color indicator for VBM junction box
- Order No. 50000671

## 8.2 Calibration solutions

### Conductivity calibration solutions CLY11

Precision solutions referenced to SRM (Standard Reference Material) by NIST for qualified calibration of conductivity measuring systems in accordance with ISO 9000

- CLY11-B, 149.6  $\mu\text{S}/\text{cm}$  (reference temperature 25 °C (77 °F)), 500 ml (16.9 fl.oz)  
Order No. 50081903
- CLY11-C, 1.406 mS/cm (reference temperature 25 °C (77 °F)), 500 ml (16.9 fl.oz)  
Order No. 50081904
- CLY11-D, 12.64 mS/cm (reference temperature 25 °C (77 °F)), 500 ml (16.9 fl.oz)  
Order No. 50081905
- CLY11-E, 107.00 mS/cm (reference temperature 25 °C (77 °F)), 500 ml (16.9 fl.oz)  
Order No. 50081906



Technical Information TI00162C

## 9 Technical data

### 9.1 Input

#### 9.1.1 Measured variables

- Conductivity
- Temperature

#### 9.1.2 Measuring range

Conductivity	Recommended range: 100 $\mu\text{S}/\text{cm}$ to 2000 mS/cm (uncompensated)
Temperature	-10 to +150 °C (+14 to +302 °F)

#### 9.1.3 Cell constant

$$k = 6.3 \text{ cm}^{-1}$$

#### 9.1.4 Temperature measurement

Pt1000 (according to DIN EN 60751)

## 9.2 Performance characteristics

### 9.2.1 Temperature response time

$$t_{90} \leq 26 \text{ s}$$

### 9.2.2 Maximum measured error

$\pm$  (0.5 % of reading + 10  $\mu\text{S}/\text{cm}$ ) after calibration

(plus uncertainty of the conductivity of the calibration solution)

## 9.3 Environment

### 9.3.1 Ambient temperature range

-20 to 60 °C (-4 to 140 °F)

### 9.3.2 Storage temperature

-25 to +80 °C (-13 to +176 °F)

### 9.3.3 Relative humidity

5 to 95 %

### 9.3.4 Degree of protection

IP 68 / NEMA type 6 (1 m (3.3 ft) water column, 50 °C (122 °F), 168 h)

## 9.4 Process

### 9.4.1 Process temperature

-10 to +125 °C (+14 to +257 °F)

### 9.4.2 Sterilization

150 °C (302 °F) / 6 bar (87 psi) absolute, (max. 60 min.)

### 9.4.3 Process pressure (absolute)

13 bar (188.5 psi) up to 90 °C (194 °F)

9 bar (130.5 psi) at 125 °C (257 °F)

1 to 6 bar (14.5 to 87 psi) in CRN environment tested with 50 bar (725 psi)

Underpressure down to 0.1 bar (1.45 psi)

### 9.4.4 Pressure-temperature ratings

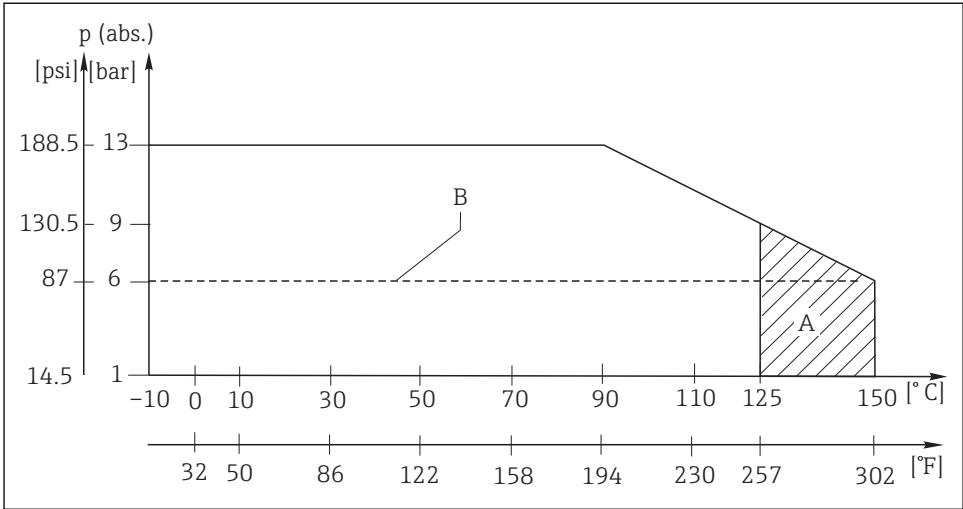

A0008379

**9** Pressure/temperature ratings

A Temporarily for sterilization (max. 60 min.)

B MAWP (maximum allowable working pressure) according to ASME-BPVC Sec. VIII, Div 1 UG101 for CRN registration

## 9.5 Mechanical construction

### 9.5.1 Dimensions

→ Section "Installation"

### 9.5.2 Weight

0.3 to 0.5 kg (0.66 to 1.1 lb.) depending on version plus cable

### 9.5.3 Materials

In contact with medium

Not in contact with medium

Virgin PEEK

PPS-GF40

Stainless steel 1.4404 (AISI 316L)

Screws: 1.4301 (AISI 304)

Cable gland: PVDF

Seals: FKM, EPDM

Cable: TPE



### 9.5.4 Surface roughness

$R_a \leq 0.8 \mu\text{m}$  (smooth, injection-molded PEEK surface) at surfaces in contact with medium

### 9.5.5 Chemical resistance

Medium	Concentration	PEEK
Caustic soda NaOH	0 to 15 %	20 to 90 °C (68 to 194 °F)
Nitric acid HNO <sub>3</sub>	0 to 10 %	20 to 90 °C (68 to 194 °F)
Phosphoric acid H <sub>3</sub> PO <sub>4</sub>	0 to 15 %	20 to 80 °C (68 to 176 °F)
Sulfuric acid H <sub>2</sub> SO <sub>4</sub>	0 to 30 %	20 °C (68 °F)
Peracetic acid H <sub>3</sub> C-CO-OOH	0.2 %	20 °C (68 °F)

# Index

## 0 ... 9

3-A . . . . . 10

## A

Accessories . . . . . 21  
Air set . . . . . 16  
Ambient temperature range . . . . . 23  
Approvals . . . . . 10

## B

Biological reactivity . . . . . 11

## C

Calibration solutions . . . . . 22  
Cell constant . . . . . 22  
Certificates . . . . . 10  
Check  
    Connection . . . . . 19  
    Installation . . . . . 17  
Chemical resistance . . . . . 25  
Cleaning agent . . . . . 20  
Connection  
    Check . . . . . 19  
    Ensuring the degree of protection . . . . . 19  
Connection conditions . . . . . 18

## D

Declaration of Conformity . . . . . 2, 10  
Degree of protection . . . . . 23  
    Ensuring . . . . . 19  
Designated use . . . . . 6  
Dimensions . . . . . 12  
Disposal . . . . . 21

## E

EC Declaration of Conformity . . . . . 2  
EHEDG . . . . . 10  
Electrical connection . . . . . 17  
Environment . . . . . 23  
Ex approvals . . . . . 10

## F

FDA . . . . . 10

## H

Hazardous areas . . . . . 7

## I

Incoming acceptance . . . . . 8  
Input . . . . . 22  
Installation . . . . . 12  
Installation conditions . . . . . 12  
Installation factor . . . . . 16  
Interpreting the order code . . . . . 9

## J

Junction box . . . . . 21

## M

Maintenance . . . . . 20  
Manufacturer's address . . . . . 10  
Materials . . . . . 24  
Maximum measured error . . . . . 22  
Measured variables . . . . . 22  
Measuring cable . . . . . 21  
Measuring ranges . . . . . 22  
Mechanical construction . . . . . 24

## N

Nameplate . . . . . 9

## O

Operational safety . . . . . 6  
Orientation . . . . . 15

## P

Performance characteristics . . . . . 22  
Post-installation check . . . . . 17  
Pressure approval . . . . . 11  
Pressure-temperature ratings . . . . . 24  
Process . . . . . 23  
Process connections . . . . . 13  
Process pressure . . . . . 23  
Process temperature . . . . . 23  
Product identification . . . . . 8, 9  
Product page . . . . . 9  
Product safety . . . . . 7

## R

Relative humidity . . . . . 23  
Repair . . . . . 20  
Requirements for personnel . . . . . 6  
Return . . . . . 20

**S**

## Safety

Electrical equipment in hazardous areas . . . 7

Safety instructions . . . . . 6

Scope of delivery . . . . . 10

## Sensor

Connecting . . . . . 18

Connection in hazardous area . . . . . 18

Mounting . . . . . 17

State-of-the-art technology . . . . . 7

Sterilization . . . . . 23

Storage temperature . . . . . 23

Surface roughness . . . . . 25

Symbols . . . . . 4

**T**

Technical data . . . . . 22

Environment . . . . . 23

Mechanical construction . . . . . 24

Performance characteristics . . . . . 22

Process . . . . . 23

Temperature measurement . . . . . 22

Temperature response time . . . . . 22

Temperature-pressure ratings . . . . . 24

Type code . . . . . 8

**U**

Use . . . . . 6

**W**

Warnings . . . . . 4

Weight . . . . . 24

Wiring . . . . . 18

Workplace safety . . . . . 6



71491463

[www.addresses.endress.com](http://www.addresses.endress.com)

---